

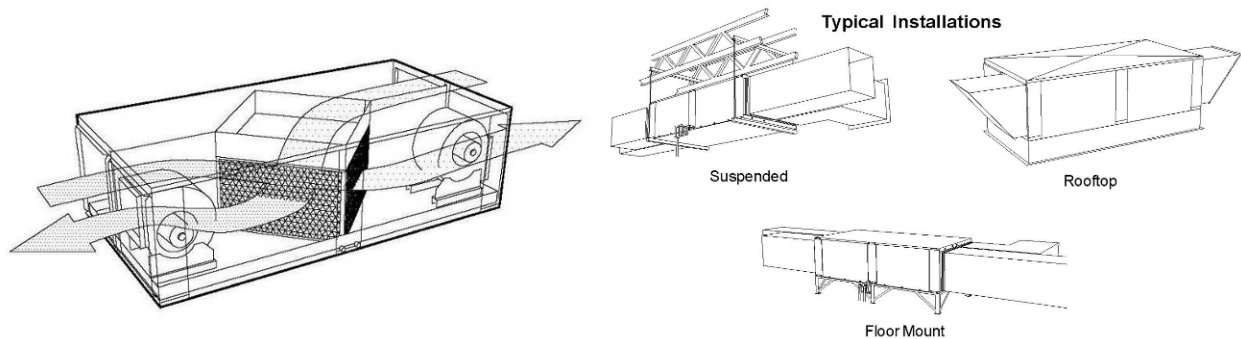

Model IAQ

Packaged, roof mounted or indoor mounted, air-to-air heat recovery ventilator in a low profile design—simple and complete, capable of many options. Ideal for schools, offices, stores, restaurants, restrooms, bars, shops, salons, etc.



- The IAQ-D is a lower capacity unit featuring a low maintenance direct drive blower system.
- The IAQ-B has a flexible design that provides a wide range of capacities, features a belt driven blower system, and can accommodate many options.

www.xetexinc.com

IAQ-D: Direct Drive Units

IAQ-500D

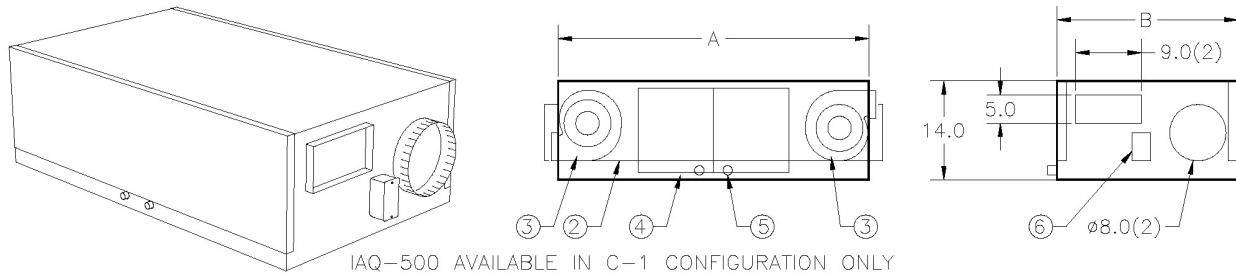

IAQ-750D to 3000D

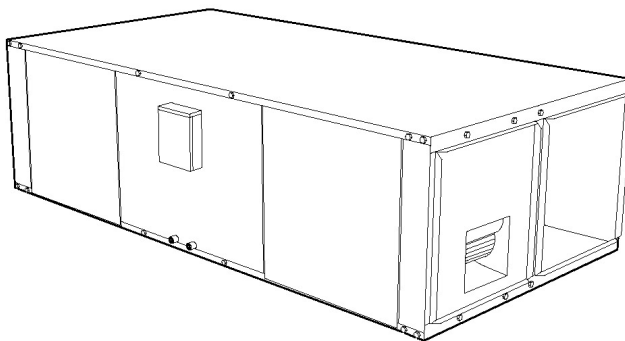

- 1 2" 30/30 TYPE PLEATED FILTERS
- ② HINGED ACCESS DOOR
- ③ FC DWDI DIRECT DRIVE BLOWER/BI OPTIONAL
- ④ ALUMINUM FLAT PLATE HEAT EXCHANGER
- ⑤ NPT DRAINS
- ⑥ NEMA 1 ELECTRICAL ENCLOSURE

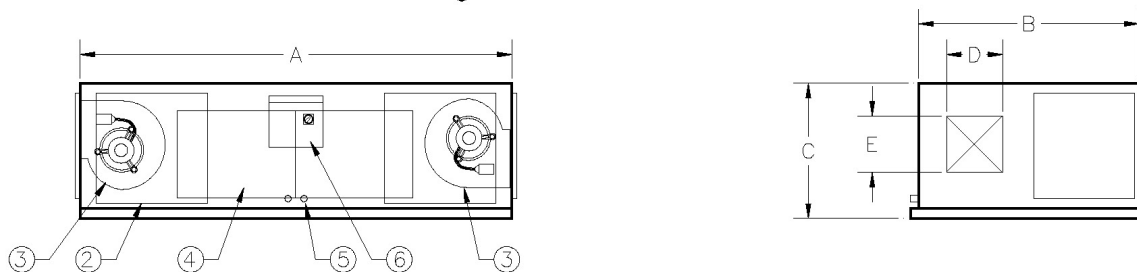

Model #	Dimension (Inches)					Bypass C & E +	XLT Type H Exchanger	Est. Weight	Nominal CFM
	A*	B	C†	D	E				
IAQ-750D	82	36	23	15	14	0	20C-12	350	500 - 700
IAQ-1500D	82	36	23	15	14	6	20C-18	400	600 - 1,100
IAQ-2500D	108	46	29	20	22	0	30G-18	650	1,000 - 1,600
IAQ-3000D	108	46	29	20	22	8	30G-24	700	1,600 to 2,400

* Does not include length of Heating Coil Section.

† Does not include custom height of Roof Curb.

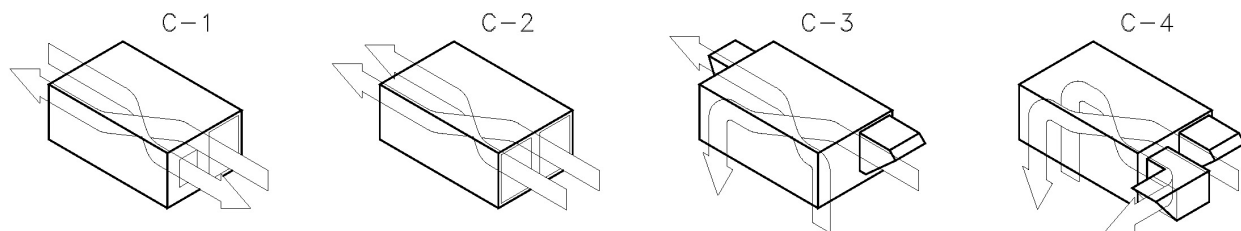

Consult factory for other available configurations.

IAQ-D: Options

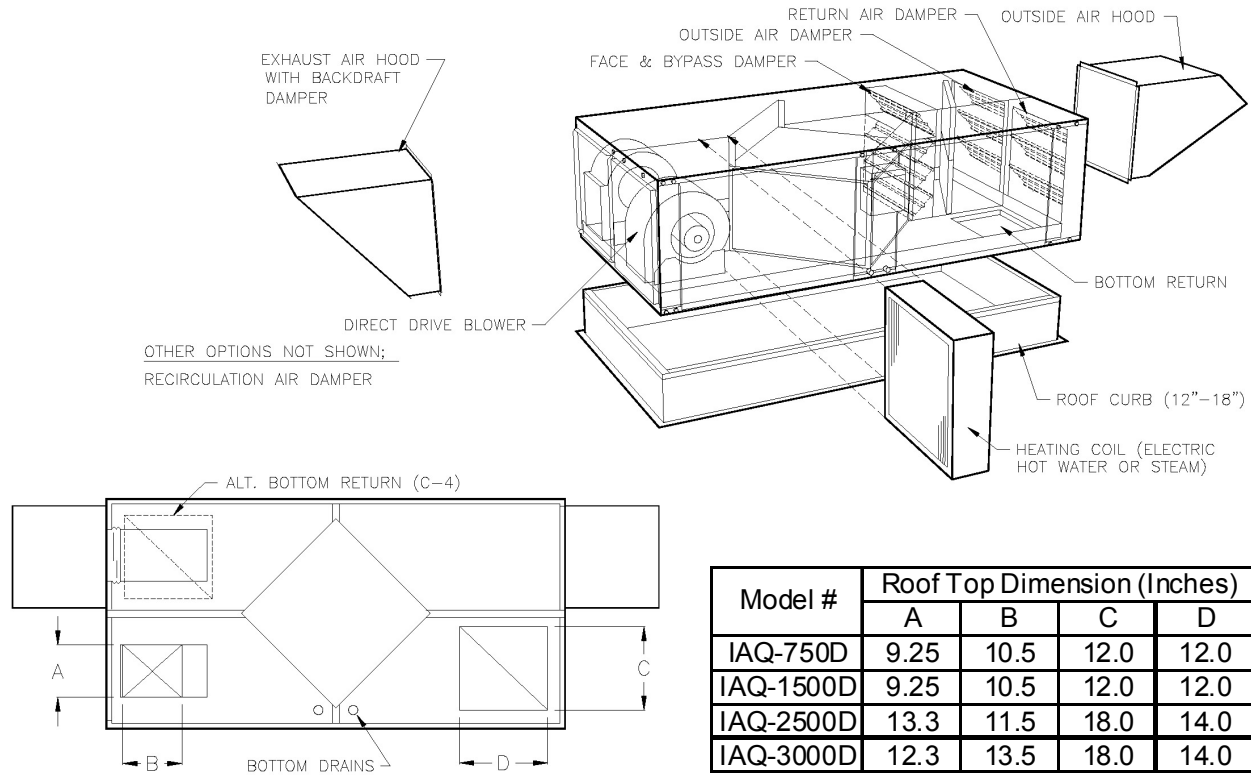

This IAQ-500D is ready for final packaging. The center door encloses the electrical panel and single point power connections and controls.



End views of an IAQ-500D. Exhaust air (top left) and supply air (bottom right) blower outlets are visible along with outdoor air (top right) and return air (bottom left) backdraft damper inlets.



Frost control is accomplished with a face-and-bypass damper operated by this actuator.

This supply air blower, like the return air blower, is arranged in a draw-through configuration.



IAQ-B: Belt Drive Units

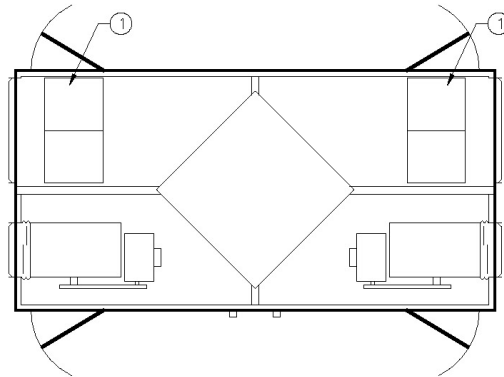
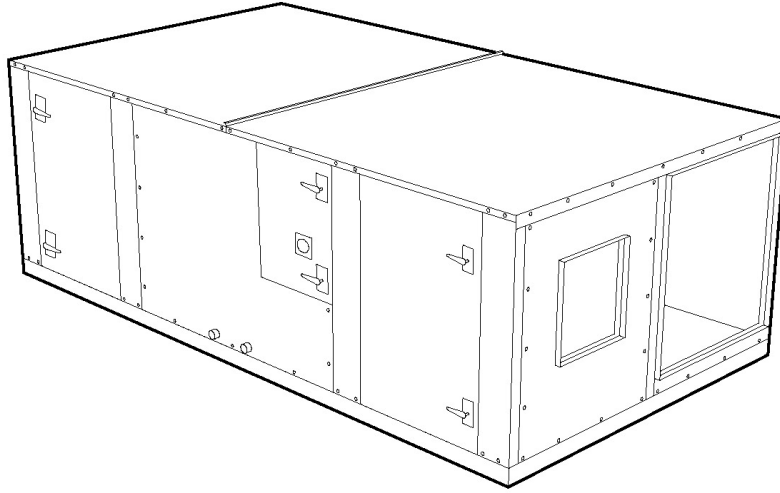

- ① 2" 30/30 TYPE PLEATED FILTERS
- ② HINGED ACCESS DOOR WITH LATCHES
- ③ FC DWDI BLOWER/BI OPTIONAL
- ④ VIBRATION ISOLATORS
- ⑤ NEMA MOTOR ODP/TEFC
- ⑥ ALUMINUM FLAT PLATE HEAT EXCHANGER
- ⑦ MPT DRAINS
- ⑧ NEMA 1 ELECTRICAL PANEL
- ⑨ OPTIONAL INDIRECT GAS FIRED HEATER

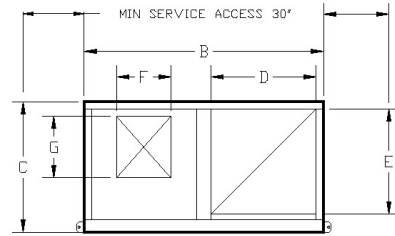
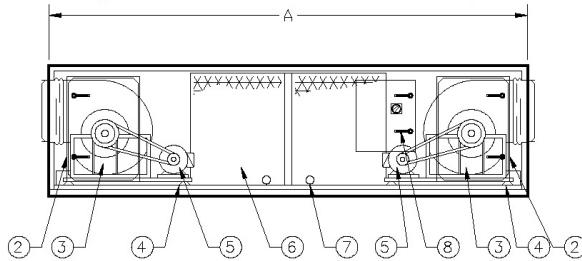
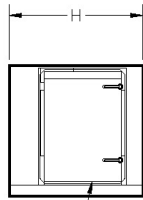

Model #	Dimension* (Inches)								Bypass C & E +	XLT Type H	Est. Weight*	Nominal CFM
	A	B	C	D	E	F	G	H				
IAQ-2500B	108	46	29	20	22	11	12	36	0	30G-18	750	1,200 - 1,750
IAQ-3000B	108	46	29	20	22	11	12	36	8	30G-24	850	1,500 - 2,300
IAQ-4000	144	66	38	30	30	16	14	42	0	40H-24	2,000	2,200 - 3,200
IAQ-5000	144	66	38	30	30	16	14	48	8	40H-30	2,500	3,200 - 4,100
IAQ-6000	156	72	42	32	34	15	16	48	12	40H-36	3,000	4,100 - 4,900
IAQ-8000	174	84	56	38	46	18	19	60	12	50I-48	5,000	5,000 - 5,900
IAQ-10000	204	96	60	42	46	20	25	60	16	60K-48	6,500	7,500 - 11,000
IAQ-12000	204	112	74	50	58	20	25	20	20	60K-60	7,000	11,000 - 14,000
IAQ-15000	240	132	104	60	86	50	28	132	24	60K-72	11,000	14,000 - 16,000

* Weights and dimensions provided as a basis of design for a base unit, no options. Consult factory for weights and dimensions of options including: gas heat, electric heat, cooling/heating coils, roof curb, etc. as overall size and weight will change significantly.

IAQ-B: Options

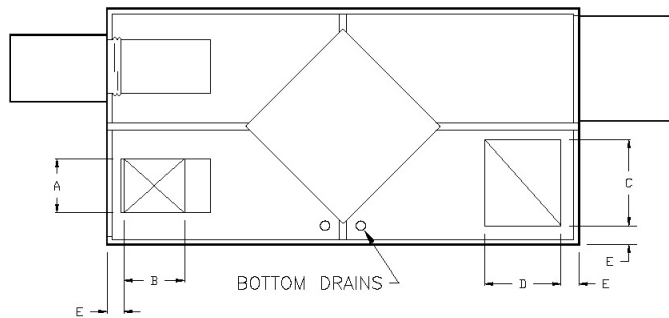
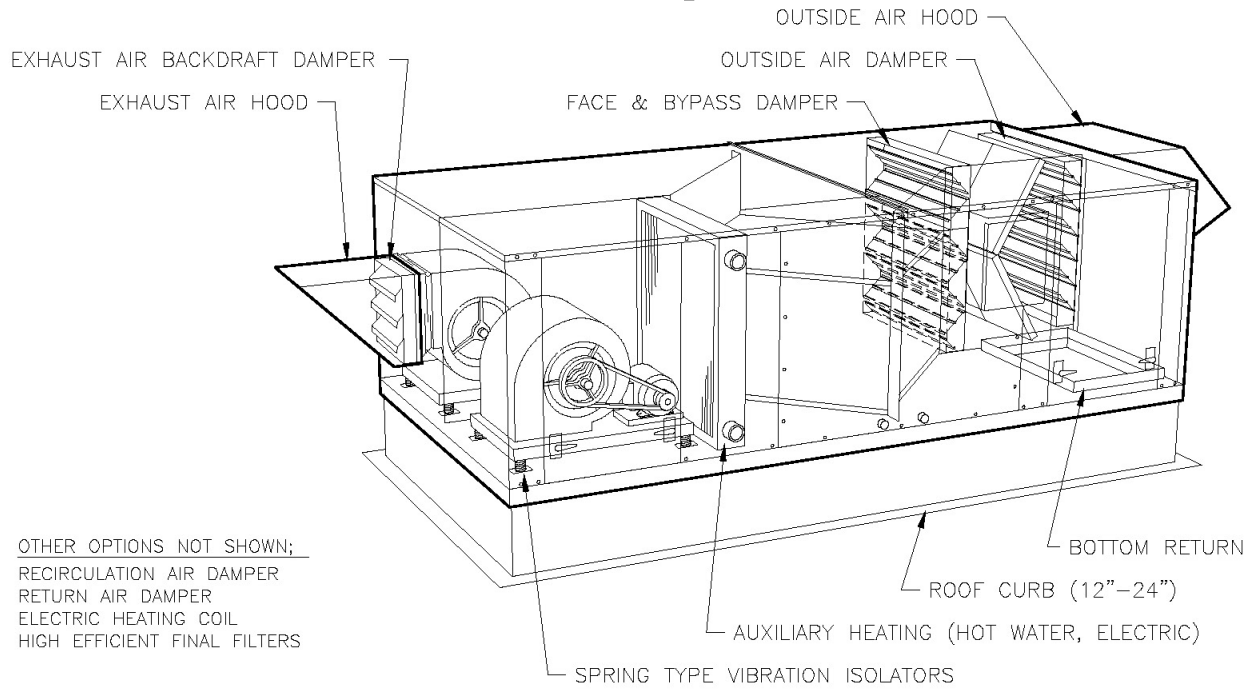

Model #	Roof Top Dimension (Inches)				
	A	B	C	D	E
IAQ-2500B	10.5	11.5	18.0	14.0	4.0
IAQ-3000B	10.5	11.5	18.0	14.0	4.0
IAQ-4000	12.5	14.0	24.0	18.0	6.0
IAQ-5000	16.0	14.0	24.0	18.0	6.0
IAQ-6000	15.0	16.0	28.0	18.0	6.0
IAQ-8000	18.0	19.0	36.0	24.0	6.0
IAQ-10000	20.0	25.0	40.0	24.0	6.0
IAQ-12000	20.0	25.0	40.0	24.0	6.0
IAQ-15000	50.0	28.0	54.0	30.0	6.0

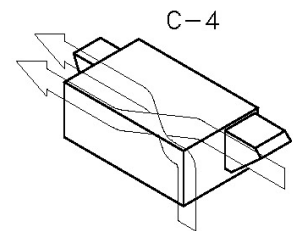
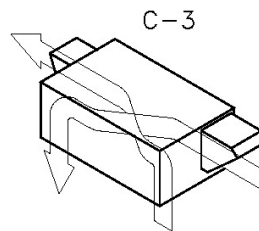
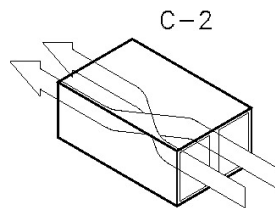
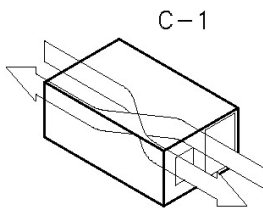

Consult factory for other available configurations.

The IAQ's low profile makes it easy to fit in small spaces. On rooftops, it also improves building appearance.



A fully-assembled IAQ-B. This unit has an integral indirect gas-fired heater and is configured for roof top installation with 1" thick double-wall construction and an all-welded galvanized steel drain pan.



Blowers are forward curved, DWDI, class I and are arranged in a draw through configuration for quiet and efficient operation. Motors are high efficient, ODP, T-frame, 1750 rpm, 1.15 service factor and are mounted on adjustable bases with variable pitch sheaves. Motor and blower are mounted on common frames, isolated from unit case with RIS (spring optional) isolators, and have flexible duct connections.



Controls: motor starters, fuses/breakers, transformer, service switch, and terminal points



The IAQ line accommodates many options. This unit has an indirect gas fired heater.

Large Capacity, Low Profile, and all the Options

This is the largest IAQ built to date. It was designed specifically for the needs and constraints of a State DOT facility. In addition to being a large capacity IAQ with cost-cutting energy recovery, this unit also features a steam heating coil, chilled water cooling coil, and custom green enamel exterior. Even with all these options, the low profile made possible by the IAQ's side-by-side airflow configuration also allowed it to be located on the building rooftop without affecting the architect's aesthetic design.

Performance Specification

Model:	IAQ-15000-RT-BP-CW
Supply cfm:	15,000
Exhaust cfm:	15,000
Built:	October 2004
Dimensions:	104" H, 264" L, 132" W
Weight:	12,500 lbs
Energy Recovered:	853 MBH (Winter) 118 MBH (Summer)
Design Conditions:	-11 °F / 45% RH (Winter) 87 °F / 55% RH (Summer)

Unit Features

- The double wall cabinet exterior is 18ga, enamel-coated, galvanealed steel insulated with 2" thick fiber-glass insulation and an 18ga galvanized interior wall. Frame is welded structural steel. Drain pans are welded stainless steel.
- 30" Supply and 22" exhaust blowers are Plenum/DWDI type belt driven by NEMA Frame, TEFC, Premium Efficiency motors (20 hp supply, 15 hp exhaust) on adjustable bases. The blowers are mounted on spring isolated frames with flexible duct connections.
- The 6-row chilled water coil is rated at 70 tons and the single row steam coil at 465 MBH.
- Dampers: Outside Air Shut-Off, Outside Air Face-and-Bypass, and Exhaust Air Backdraft
- 2" MERV 8 filters on both outdoor and return airstreams protect the unit from debris.
- Single Point Power electrical panel includes main disconnect, motor starters, and branch circuit breakers.



Model IAQ Unit Specification

Contractor shall provide a Model IAQ packaged, (roof mounted/indoor mounted), air-to-air heat recovery ventilator as manufactured by Xetex, Inc. Unit to include aluminum flat plate exchanger, supply air and exhaust air blowers, motors with starters and relays, outside air filters, adjustable defrost control, and specified options.

Unit shall have a welded structural steel base frame with integral lifting lugs. Frame shall be coated with rust inhibiting paint. Lower floor shall have a sub-floor of 22 gauge galvanized steel, formed structural supports with rigid closed cell load-bearing insulation under blowers and components, and an interior floor of 16 gauge galvanized steel.

Cabinet frame shall be of formed 18 gauge (minimum) galvanized steel exterior. Panels (fixed and access) to be of 18 gauge galvanized steel with [1", 1.5"] thick, 3# density, hardboard fiberglass insulation with reinforced aluminum lining secured with metal fasteners and sealed with aluminum tape and silicone sealant to provide a complete vapor barrier and non-contaminating surface to all airstreams (optional insulated 22 gauge double wall 1", 1.5", 2"). Framing and panels of dissimilar metals that could create a galvanic effect are not allowed. Optional fully painted exterior with 2 coats minimum of High Performance Acrylic over galvanealed sheet metal. Exchanger section shall have a full width drain pan, minimum 3" deep, with MPT drains on supply and exhaust air plenums.

Provide access to all exchanger surfaces, blowers, motors, and filters, through double walled, hinged, and gasketed access doors. Doors shall be held closed by a minimum of two roller cam latches. Continuous hollow rubber gasket shall be applied to all access openings to provide water and airtight seals. Door hinges shall be galvanized steel.

Air-to-air heat exchanger shall be an XLT stationary, aluminum, flat-plate type manufactured by Xetex. Heat transfer surface shall be formed aluminum plates with enhanced surface corrugation for increased performance. Exchanger shall be capable of withstanding a pressure difference between airflows of up to 7.2" w.g. without deforming air passages. Unit shall be capable of operating in temperatures up to 190°F. Standard cell construction shall have a maximum cross contamination between airflows of 0.1% of total airflow. The entire cell shall be capable of being visibly inspected and cleaned as required.

Blowers shall be forward curved, DWDI, class I, and arranged in a draw through configuration relative to exchanger for quiet and efficient operation. Direct drive motors shall be efficient, multi-speed, PSC type with internal thermal overload protection. Belt drive motors are to be high efficiency, ODP, T-frame, nominal 1750 rpm, 1.15 service factor minimum, and mounted on an adjustable base with variable pitch sheaves. Motor and blower to be mounted on a common frame and isolated from unit case with RIS isolators and flexible duct connections. Motors and blowers shall have V-belt drives with variable pitch sheaves. Belt drive fans shall have a hollow rubber gasket around the fan discharge to provide an airtight seal while allowing for easy removal and replacement of the fan without screws or permanent fasteners. The discharge gasket shall isolate the fan from the unit casing and eliminate the requirement for an expansion duct fitting.

Electrical controls shall include motors with internal thermal protection and relays for direct drive units, motor starters with overloads for belt drive units, fused branch circuit breakers, control transformer for 24V low voltage controls, service switch, and terminal points.

Outdoor air and return air filters shall be 2" pleated 30/30 type. Filters shall be mounted within unit in galvanized holding frames upstream of exchanger and accessible through access panels.

Dampers shall have heavy duty extruded aluminum frames and 4" extruded aluminum air-foil blades mounted on brass shafts and supported and inter-connected by nylon gears. Low leakage dampers shall have hollow rubber jamb seals built into both the blades and the frame. The side casings shall enclose the gears with ABS plastic covers that also serve as seals in the closed position. Outside air dampers shall be mounted on the inlet of the unit and operated by a spring return direct-coupled actuator with an end switch to be interlocked with the supply air motor relay. Exhaust air backdraft damper to be parallel blade. Face-and-bypass dampers shall be interlocked so that when the face damper is open the bypass damper shall be closed.

Weatherized outdoor construction shall include sloped roof panels with rain gutters that overhang the sidewalls to shed water away from access panels, capped roof seams, intake and exhaust weather hoods with bird-screens, outside air shut-off damper, and exhaust air backdraft damper. Secondary roof panels that could trap moisture are not allowed. Roof curb shall be 16 gauge (minimum) galvanized steel with additional supports and cross members as needed. Curb to have 1.5" thick fiberglass insulation and wood nailer.